

CIRCULAR INTERFEROMETER SIMULATION

Reuben Shar, ADI Limited, Garden Island 2011 NSW

Electronic Support Measures (ESM) systems use different methods for direction finding (DF). A Circular Interferometer is one of the DF methods used [Ref 1)]. A Circular Interferometer uses a circular array of omni-directional antenna elements and a Butler Matrix to generate phase difference output that is related to the direction of arrival (DOA) of electromagnetic waves. This paper describes an approach to simulation of circular interferometer performance using Method-of-Moments antenna simulation and spreadsheet based post-processing. Sample DF accuracy results are discussed and compared to published specifications. This work is based on analysis conducted on the ESM system for the Surface Combatant Force Guided Missile Frigates (FFG) Upgrade project.

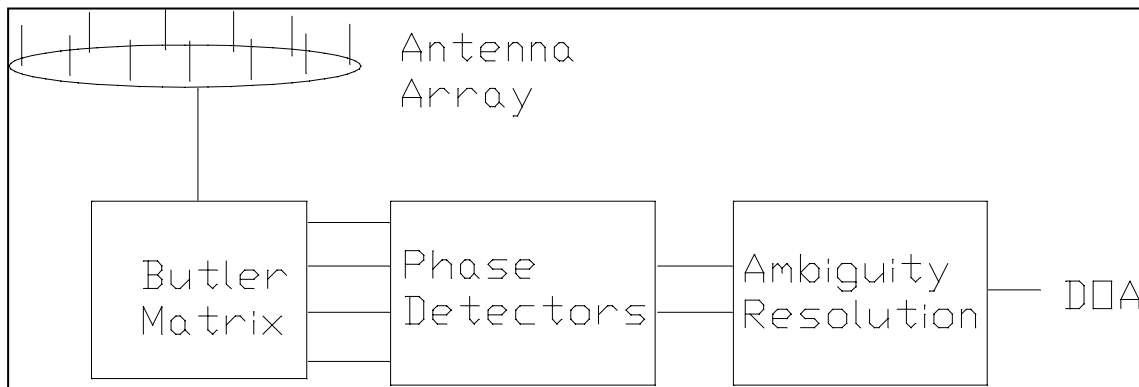

The paper describes the principle of operation of a circular phase interferometer. It starts with a simplified geometric approach to phase values at each element. At the next stage it uses a Method-of-Moments simulation of an antenna array to produce the phase values. The element phase values are fed into a mathematical 'Butler matrix' and phase detection to calculate the outputs of different phase modes. The following plot shows a sample of modal phase outputs for Mode 0, +1 and +2, as a function of the DOA (θ_j) of the incident wavefront, both in degrees.

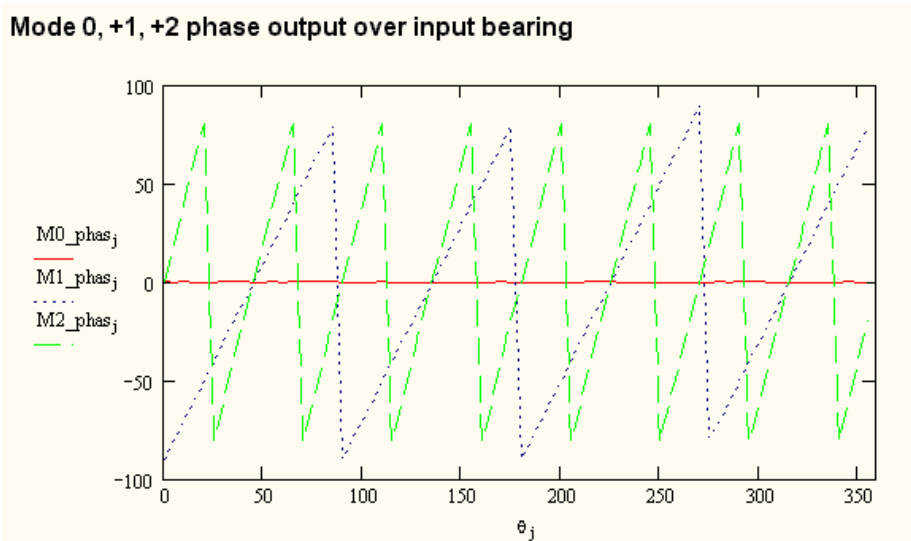

The direction-of-arrival of the incident wavefront is resolved for ambiguous modes, and performance data compared to that available in the literature.

References:

- 1) 'Microwave Passive Direction', by Stephen E. Lipsky, 2003 SciTech.